

PIANTA (PLAN)

5050

4550

1550

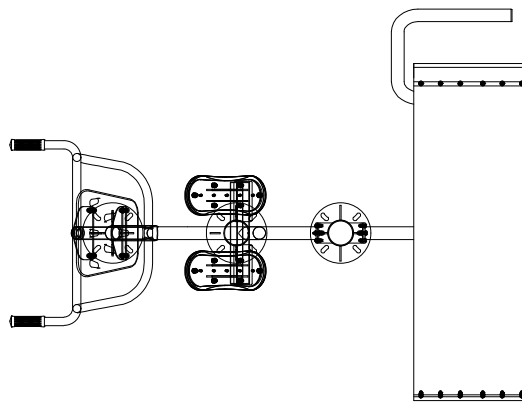

2050

AREA DI SICUREZZA (SECURITY AREA) 23 MQ

SCHEDA TECNICA (TECHNICAL DATA SHEET)

ART. T0010509

06-06-2024

SCALA (SCALE) 1:30

LE MISURE SONO ESPRESSE IN MM. (MEASUREMENTS ARE EXPRESSED IN MM.)



TIEGI SRL
VIA BENEDETTO CROCE 7,
Z.I. "CONDOTTI BARDINI",
31058 SUSEGANA (TV),
0438-460519

FOGLIO 2 DI 5



ALTEZZA DI CADUTA MAX.
(MAX. FALL HEIGHT): <100 cm



INGOMBRO (OVERALL DIMENSION)
205 cm X 155 cm X 96 cm H.



NUMERO UTILIZZATORI 2
(MAX N. OF SIMULTANEOUS USERS)



AREA DI SICUREZZA (SECURITY AREA)
455 cm X 505 cm



SUP. ANTITRAUMA CONSIGLIATA
(RECOMMENDED SAFETY SURFACING AREA)
23 MQ.



ALTEZZA D'USO (HEIGHT USE)
>140 cm

SCHEDA TECNICA (TECHNICAL DATA SHEET)

ART. T0010509

06-06-2024

SCALA (SCALE)

LE MISURE SONO ESPRESSE IN MM. (MEASUREMENTS ARE EXPRESSED IN MM.)



TIEGI SRL
VIA BENEDETTO CROCE 7,
Z.I. "CONDOTTI BARDINI",
31058 SUSEGANA (TV)
0438-460519

FOGLIO 3 DI 5

**SUPPORTI E LAMIERA IMBOTTITI
CON RIVESTIMENTO**

(UPHOLSTERED SUPPORTS AND SHEET)

MANOPOLE ZIGRINATE

(KNURLED HANDLES)

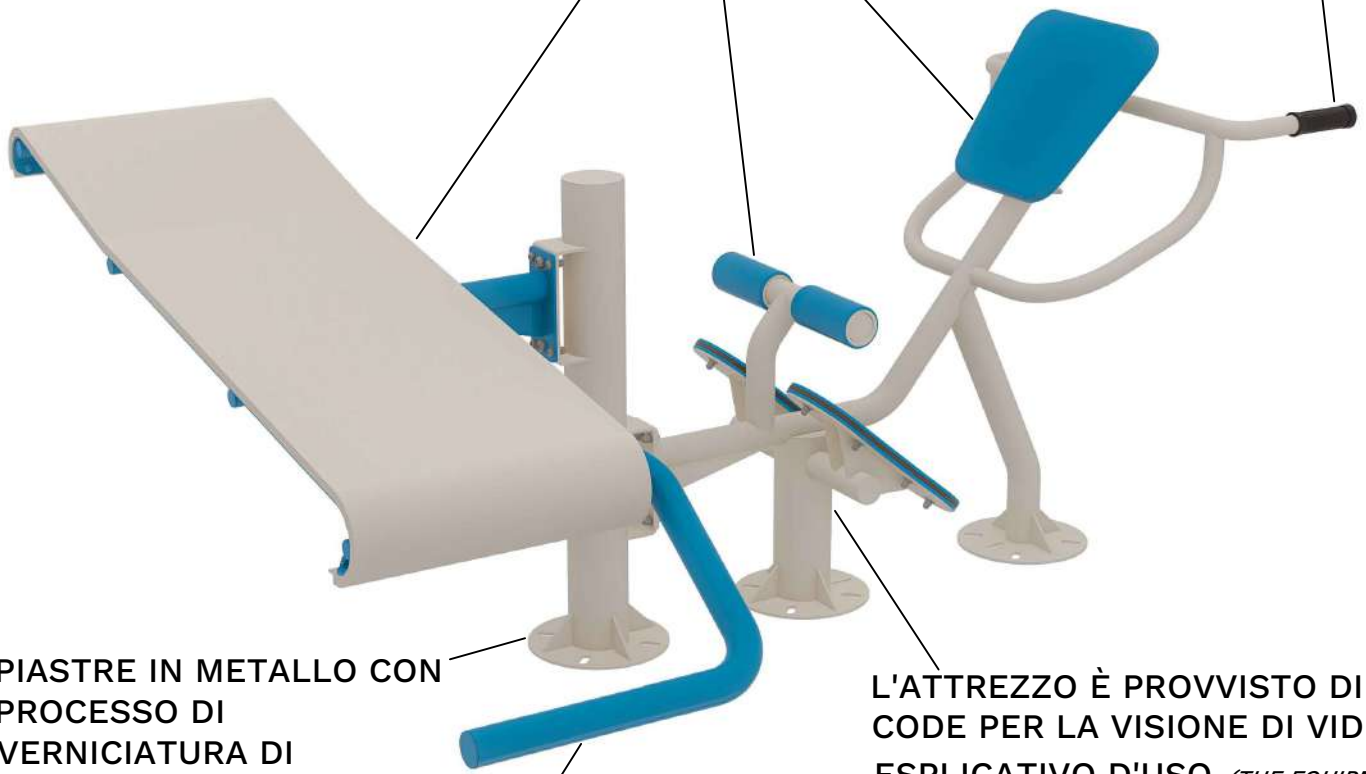

**PIASTRE IN METALLO CON
PROCESSO DI
VERNICIATURA DI
CATAFORESI, PRIMER E
VERNICIATURA
TERMOINDURENTE 180°C**

*(METAL PLATES WITH CATAPHORESIS,
PRIMER AND 180°C THERMOSETTING
PAINTING PROCESS APPLIED)*

**TUBI IN METALLO CURVATI.
PROCESSO DI VERNICIATURA
PER CATAFORESI, PRIMER E
VERNICIATURA
TERMOINDURENTE 180°C**

*(CURVED METAL TUBES. CATAPHORESIS,
PRIMER AND 180°C THERMOSETTING PAINTING
PROCESS APPLIED)*

**L'ATTREZZO È PROVVISORIO DI QR
CODE PER LA VISIONE DI VIDEO
ESPLICATIVO D'USO** *(THE EQUIPMENT
IS PROVIDED WITH A QR CODE, DISPLAYING AN
EXPLANATORY VIDEO OF THE EXERCISE)*

**TUTTI GLI ELEMENTI DI FISSAGGIO,
VITI, DADI, RONDELLE ECC. SONO IN
ACCIAIO INOX**

*(ALL FASTENERS, SCREWS, NUTS, WASHERS, ETC. ARE
MADE OF STAINLESS STEEL)*

SCHEMA TECNICO (TECHNICAL DATA SHEET)

ART. T0010509

06-06-2024

SCALA *(SCALE)*

LE MISURE SONO ESPRESSE IN MM. (MEASUREMENTS ARE EXPRESSED IN MM.)



TIEGI SRL
VIA BENEDETTO CROCE 7,
Z.I. "CONDOTTI BARDINI",
31058 SUSEGANA (TV)
0438-460519

FOGLIO 4 DI 5

VISTA FRONTALE
(FRONTAL VIEW)

ALTEZZA MASSIMA DI
CADUTA LIBERA
(MAXIMUM HEIGHT OF THE
FREE FALL): < 100 cm

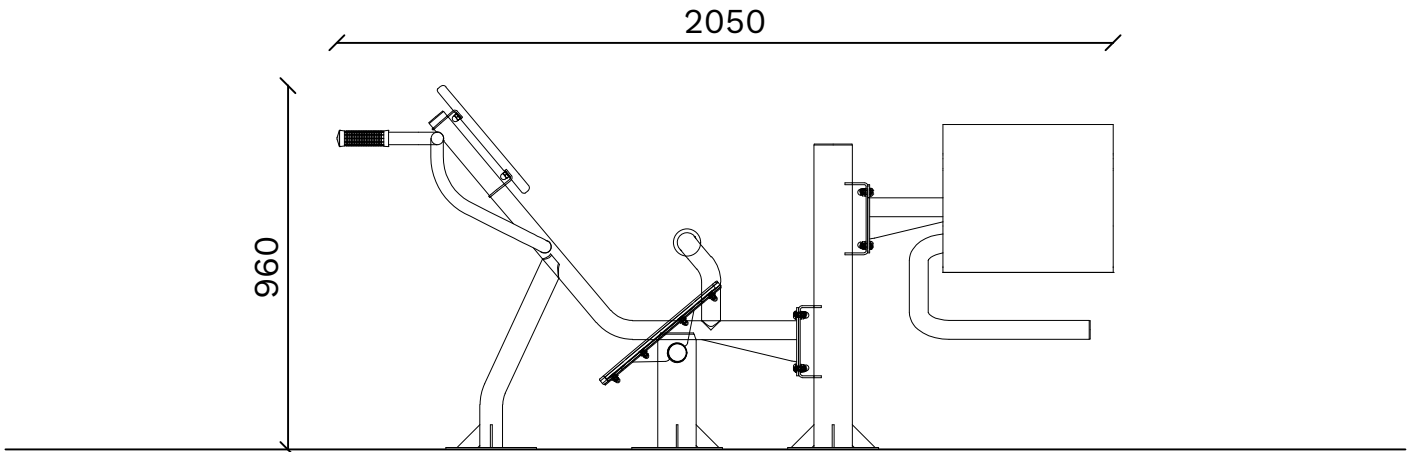

VISTA LATERALE
(LATERAL VIEW)

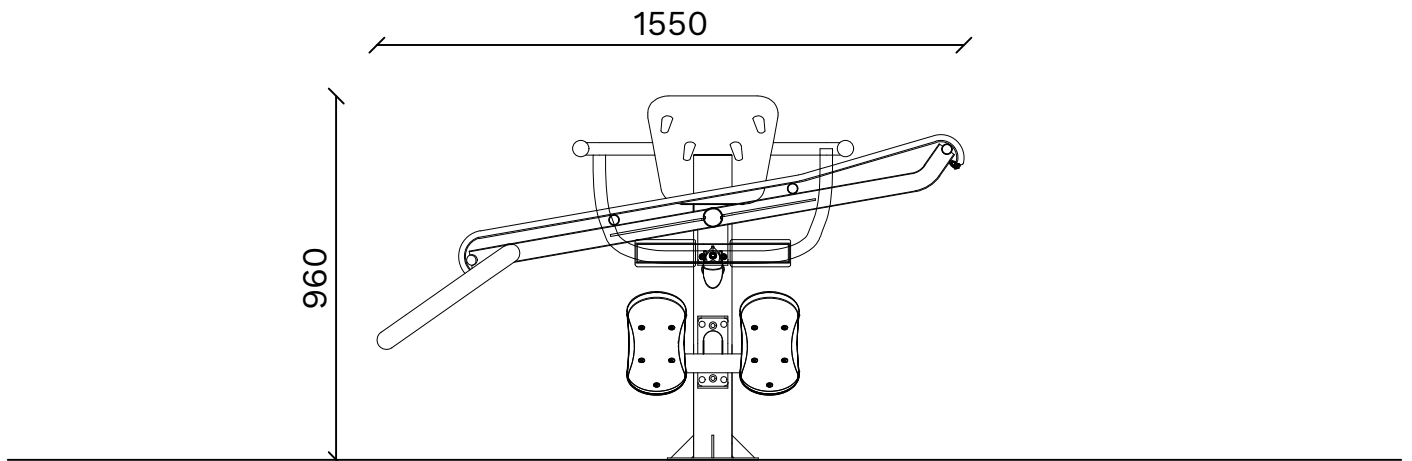

INGOMBRO MAX (OVERALL DIMENSIONS)

SCHEDA TECNICA (TECHNICAL DATA SHEET)

ART. T0010509

06-06-2024

SCALA (SCALE) 1:20

LE MISURE SONO ESPRESSE IN MM. (MEASUREMENTS ARE EXPRESSED IN MM.)



TIEGI SRL
VIA BENEDETTO CROCE 7,
Z.I. "CONDOTTI BARDINI",
31058 SUSEGANA (TV)
0438-460519

FOGLIO 5 DI 5